

# CDD14/16

## 1.6 Ton Straddle Electric Stacker

Lifting Height: 1400-5800mm

### Load Curve

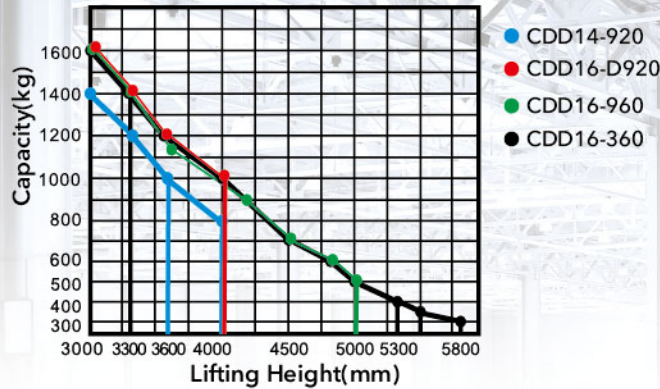

### Advantages

#### Configuration and Performance

- Electronic power steering system, light and low noise.
- Two-way magnetic valve, three drop speed mode.
- Drive unit floating bodies with patent design.
- AC Driving system, No carbon brush, maintenance free.
- USA CURTIS driving controller.
- Electromagnetic, regenerative braking system.
- Automatic lifting limit, proximity switch, long life.

#### Safety

- Curve automatic deceleration devices, more safe.
- Vehicle decelerates automatically at higher position.
- Stepless speed control system, safe and quiet.
- Controller with Multiple automatic protection.
- Emergency reversing device/Emergency brake switch.
- High position automatic reduction device.

#### Economical straddle typed stacker

Steering automatic deceleration

AC | EPS Down mode at 3 speeds

Truck automatically decelerates while at higher lifting position

Type	Lift height (mm)	Mast type	Outside width between legs (mm)	Inside width between legs (mm)
CDD14-920	1400/2000/2500/3000/3300/3600/4000	Standard 2-STAGE	1170/1320/1470/1650	970/1120/1270/1450
CDD16-D920	1400/2000/2500/3000/3300/3600/4000	Standard 2-STAGE		
CDD16-960	3700/3900/4200/4500/4700/5000	FULL FREE 3-STAGE		
CDD16-360	5300/5500/5800	FULL FREE 3-STAGE		

Feature					
Model		CDD14	CDD16	CDD16	CDD16
Configuration No.		920	D920	960	360
Type		Wide legs	Wide legs	Wide legs	Wide legs
Mast type		Standard 2-Stage	Standard 2-Stage	Full free 3-Stage	Full free 3-Stage
Load capacity	kg	1400	1600	1600	1600
Load center	mm	600	600	600	600
Wheel base	mm	1310	1310	1375	1375
Operating type		Walkie/Stand On			
Wheels					
Wheels type		PU	PU	PU	PU
Wheel quantity Driving wheel/ Balance wheel/Bearing wheel		1/2/4	1/2/4	1/2/4	1/2/4
Dimension					
Standard lift height	mm	1400/2000/2500/3000/ 3300/3600/4000	1400/2000/2500/3000/ 3300/3600/4000	3700/3900/4200/ 4500/4700/5000	5300/5500/5800
Lowered fork height	mm	55	55	55	85
Fork size(length/width/thickness)	mm	1070/100/40	1070/100/40	1070/100/40	1070/100/40
Overall length	mm	2005/2425	2005/2425	2073/2493	2073/2493
Overall width	mm	1470	1470	1470	1470
Max.extend height	mm	1900/2500/3000/3500/ 3800/4100/4500	1900/2500/3000/3500/ 3800/4100/4500	4200/4400/4700/ 5000/5200/5500	5800/6000/6300
Mast lowered height	mm	1185/1535/1765/1980/ 2135/2335/2500	1185/1535/1765/1980/ 2135/2335/2500	1800/1900/1985/ 2085/2135/2235	2520/2590/2690
Min.Turning radius	mm	1565/1975	1565/1975	1630/2040	1630/2040
Min.Aisle width for pallets 800×1200	mm	2230/2560	2230/2560	2230/2625	2230/2625
Min.Aisle width for pallets 1000×1200	mm	2260/2585	2260/2585	2260/2650	2260/2650
Min.ground clearance	mm	50	50	50	30
Performance					
Travel speed,laden/unladen	km/h	5/5	5/5	5/5	5/5
Lift speed,laden/unladen	mm/s	130/230	130/230	130/230	130/230
Lowering speed,laden/unladen	mm/s	130/230	130/230	130/230	130/230
Gradeability,laden/unladen	%	5/7	5/7	5/7	5/7
Electrical configuration					
Drive motor/Lift motor/Steering motor	kW	AC1.5/DC3/DC0.15	AC1.5/DC3/DC0.15	AC1.5/DC3/DC0.15	AC1.5/DC3/DC0.15
Battery voltage	V	24	24	24	24
Battery capacity	Ah	280	280	280	280
Brake		Electromagnetic/Regenerative			
Controller		CURTIS			
Weight					
Battery weight	kg	250	250	250	250
Service weight with battery	kg	1300	1370	1648	1680

\* Details of specifications and equipment are based on information available at time of printing and may change without notice.



#### ANHUI HELI INDUSTRIAL VEHICLE IMP. AND EXP. CO., LTD.

ADD: 668 FANGXING ROAD, HEFEI, ANHUI, CHINA  
TEL: +8655163639068  
FAX: +8655163639966  
Email: heli@helichina.net  
WEBSITE: WWW.HELICHINA.COM / WWW.HELICHINA.NET



## CDD16-960H 3500lbs (1600 kg)

### 3500lbs (1600 kg) Electric 24V Pallet Stacker CDD16-960H



High efficiency hydraulic pump delivers power and performance

Rugged structure and cover is designed for durability

Electronic power steer system is responsive and quiet

CDD16-960H has multiple safety features including automatic deceleration in turns

Emergency reverse switch and emergency brakes help ensure safe operation

Small turning radius make the CDD16-960H easy to use in narrow aisles

AC drive motor is powerful and maintenance free

Steel grid finger guard comes standard on all units

Side operating stance makes truck highly maneuverable and gives operator a broader view

Handle integrates keyswitch and meter to make operation easy and convenient

Unit comes standard with Curtis controls, which incorporate multiple, automatic protection

The lifting / lowering system has been greatly improved with three speed lowering mode, automatic lift limiting and high lift speed automatic adjustment



Top 10 Forklift  
Manufacturer In The World

#### Manufacturer's Data and Design Characteristics

##### Characteristics

1.1	Manufacturer					<b>HELI</b>									
1.2	Model					CDD16-960H									
1.3	Operator type					Walkie									
1.4	Rated Capacity	Q	lb	kg	3500					1600					
1.5	Mast Type					Full free 3-stage									
1.6	Load center	c	in	mm	23.6					600					
1.7	Wheelbase	y	in	mm	45.9					1330					
1.8	Distance - axle centerline to fork face	x	in	mm	28.3					697					

##### Wheels

2.1	Tire type	Polyurethane									
2.2	Wheel - number drive, balance, load	1/2/4									

##### Dimensions

3.1	Lift Height	h3	in	mm	145.7	3700	153.5	3900	165.4	4200	177.2	4500	185.0	4700	196.8	5000
3.2	Mast height - extended	h1	in	mm	165.4	4200	173.2	4400	185.0	4700	196.8	5000	204.7	5200	216.5	5500
3.3	Mast height - lowered	h4	in	mm	70.9	1800	74.8	1900	78.1	1985	82.1	2085	84.1	2135	88.0	2235
3.4	Fork height - lowered	h13	in	mm	2.2					55						
3.5	Fork dimensions	s/e/L	in	mm	1.6 / 3.9 / 42.1					40 / 100 / 1070						
3.6	Overall length	L1	in	mm	75.2					1910						
3.7	Overall width - chassis	b1	in	mm	31.5					800						
3.8	Min. turning radius	Wa	in	mm	59.1					1500						
3.9	Aisle with 40" x 48" (1000x1200) pallet		in	mm	79.9					2030						
3.10	Aisle with 32" x 48" (800x1200) pallet		in	mm	72.8					1850						
3.11	Min. ground clearance	m2	in	mm	2.0					50						
3.12	Outrigger width - outside	b2	in	mm	57.9					1470						

##### Performance

4.1	Travel speed (with / without load)	mph	km/h	3.1 / 3.4					5.0 / 5.5				
4.2	Lift speed (with / without load)	in/s	mm/s	5.1 / 7.5					130 / 180				
4.3	Lower speed (with / without load)	in/s	mm/s	3.9 / 7.5					100 / 180				
4.4	Max. gradeability (with / without load)	%	5 / 7										

##### Electrical

5.1	Drive motor type / rating	hp	kW	AC / 2.0					AC / 1.5				
5.2	Lift motor type / rating	hp	kW	DC / 4.0					DC / 3.0				
5.3	Steer motor type / rating	hp	kW	DC / 0.2					DC / 0.15				
5.4	Service brake type	Electromagnetic / Regenerative											
5.5	Controller	Curtis											
5.6	Battery voltage / rated capacity	V/Ah	24 / 270										

##### Weight

6.1	Battery weight ( ±5%)	lb	kg	540					245				
6.2	Service weight (with 63" [1600mm] mast)	lb	kg	3330					1510				

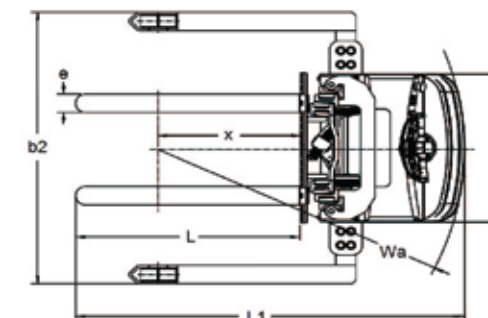
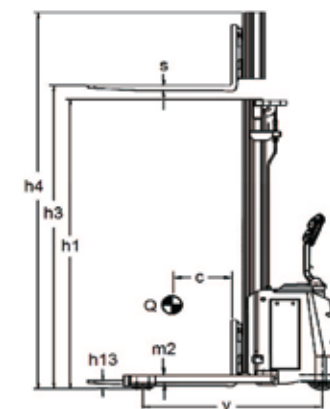

**ANHUI HELI CO., LTD.**

Corporate: [www.helichina.net](http://www.helichina.net)

US East: [www.heliamericas.com](http://www.heliamericas.com)

US West: [www.industrialforklifts.com](http://www.industrialforklifts.com)

Canada: [www.heliforklift.ca](http://www.heliforklift.ca)

AUTHORIZED DEALER